

Therma-Tru[®] Hinged Patio Door System

Double Door “French” Unit Assembly

Read all instructions before starting.

The applicable standards for these products are governed by
the International Residential Code.
Copies of performance ratings and testing are available on our website
www.thermatru.com and our product manual.

Part identificaion

Not all parts shown will be included in package.
Parts will vary for type of unit purchased.

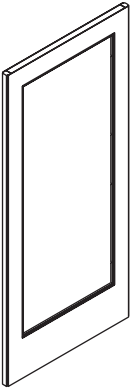

Door Panel

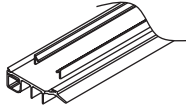

Door Bottom

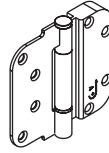

Adjustable Hinge

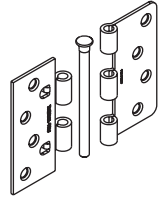

Standard Hinge

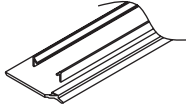

Door Bottom -
Outswing

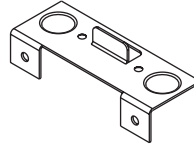

Transport Clip

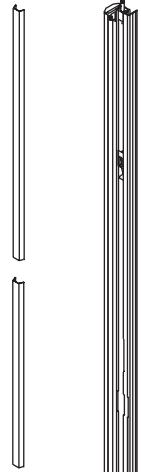

Snap-In
Cover

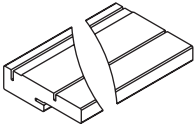

Head Jamb

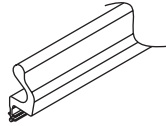

Head & Lock
Weatherstrip

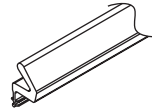

Hinge
Weatherstrip

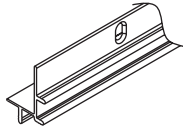
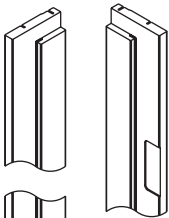

Inswing Flange

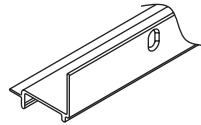

Outswing Flange

Astragal

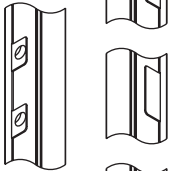

Lock
Jamb



Hinge
Jamb

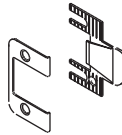

Standard
Strike



Deadbolt
Plate



Corner Seal
Pad

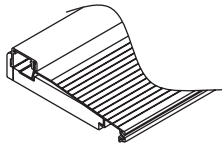

Inswing sill

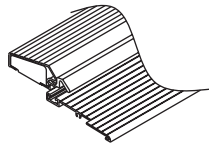

Outswing Sill



End Seal Pad

Part identification - continued



Multi-point Lock
Jamb Strike

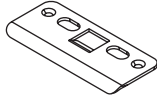

Multi-point Lock
Head Strike

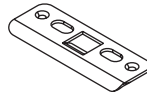

Multi-point Lock
Sill Strike -
Inswing

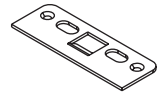

Multi-point Lock
Sill Strike -
Outswing

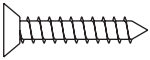

#6 x 3/4"
flat head screw

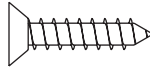

#8 x 3/4"
flat head screw

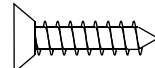

#10 x 3/4"
flat head screw

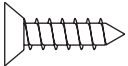

#8 x 5/8"
flat head screws

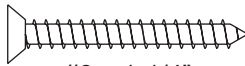

#8 x 1-1/4"
flat head screw

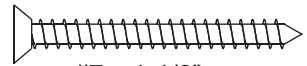

#7 x 1-1/2"
flat head screw

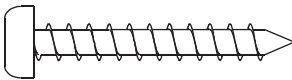

#10 x 1 1/2"
pan head screw

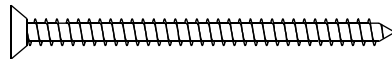

#8 x 2"
flat head screw

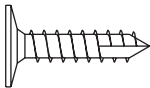

#8 x 3/4"
wafer head screw

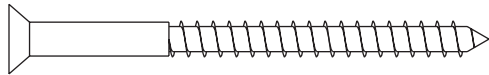

#10 x 2-1/2"
flat head screw

Tools/materials required

This is a listing of tools that may be required to assemble unit.

- Drill/screw gun
- Phillips head drive bit or screwdriver #2 & #3
- Silicone sealant and caulk gun
- Utility knife
- Rubber mallet
- Hammer
- 1/16", 3/32" & 1/8" dia. drill bit
- (2) 3/4" thick x 6' long boards



NOTE:

A large work area is needed to assemble the frame kit. Cover area with cardboard from one or more door panel cartons to protect frame parts and floor. If available a carpeted table can be used to avoid marring prefinished surfaces.

1 REMOVE COMPONENTS FROM PACKAGING

NOTE:

Product that is purchased with the multi-point lock system will have additional instructions in the handle hardware box.

Installation instructions will be included in the site package.

2 ATTACH HINGES TO DOOR

Standard Hinge Option

Use Correct Hinge Leaf

Leaves applied to door have 2 knuckles.

Leaves applied to jamb have 3 knuckles.

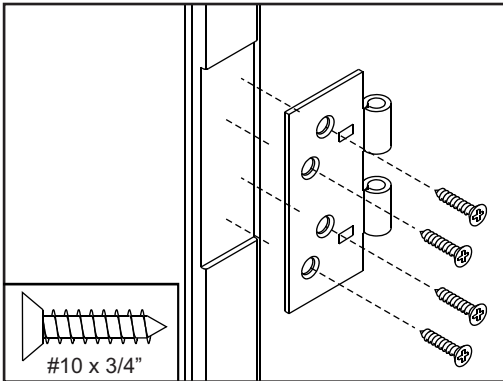
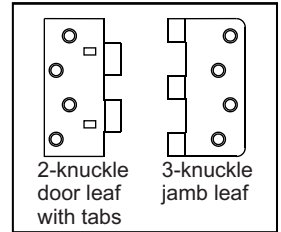

Align and Install Hinges

Place tabs firmly against door.

Fasten 2-knuckle hinge leaves with #10 x 3/4" flat head screws.

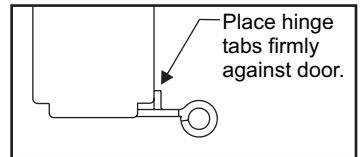

NOTE:

Outswing packages come with a non-removable pin (NRP) hinge. It is recommended to attach the hinge in the middle location. For 8' heights, two NRP hinges are included. NRP hinges have locating tabs. Fasten to door panel using same method as for unassembled hinges, placing tabs against door face to locate hinge.

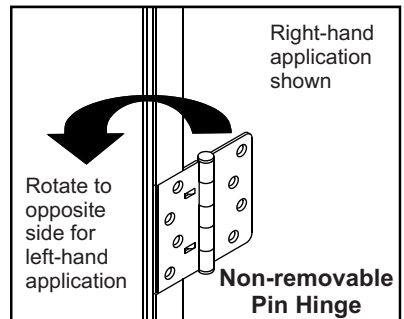

2 ATTACH HINGES TO DOOR - *continued*

Adjustable Hinge Option

Attach hinge to door

Locate the “H” and “V” markings on hinges. The two “H” hinges go in top and bottom locations with the “V” hinge in the center.

For 8', the “V” hinge is located second from top of door.

Insert thick side of hinge into pocket in door and fasten with #8 x 1-1/4" flat head screws.



NOTE:

Inswing hinges are reversible by removal of hinge pin. Outswing hinges are reversible by removal of set screw then removal of hinge pin.

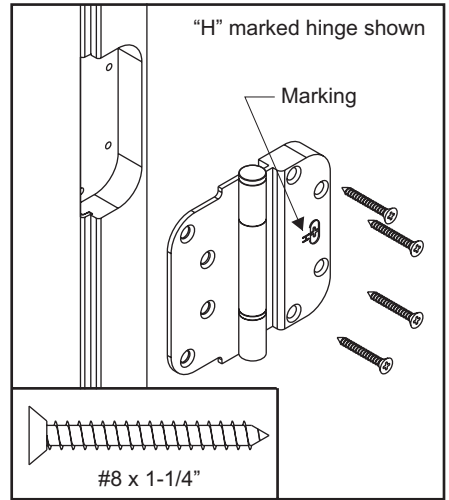

3 INSTALL DOOR BOTTOM

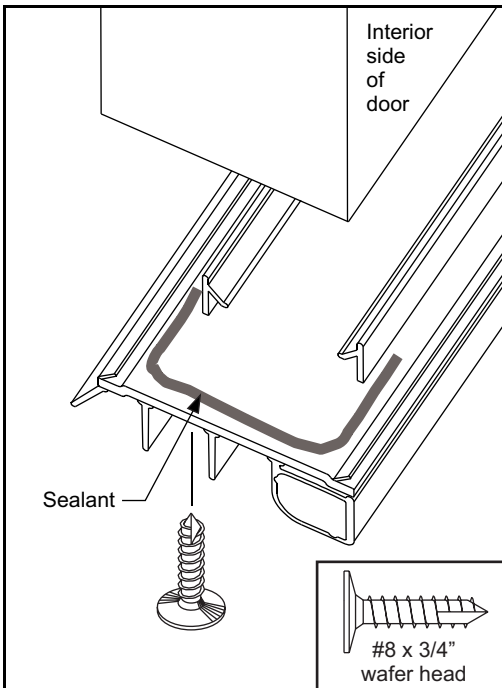

Caulk and Fasten Door Bottom

Select a sealant that provides excellent adhesion to both plastic and wood.

Apply sealant as shown to ends of door bottom.

Center door bottom and press into rail kerfs.

Secure each end of door bottom with (1) #8 x 3/4" wafer head screw.

4 ATTACH ASTRAGAL

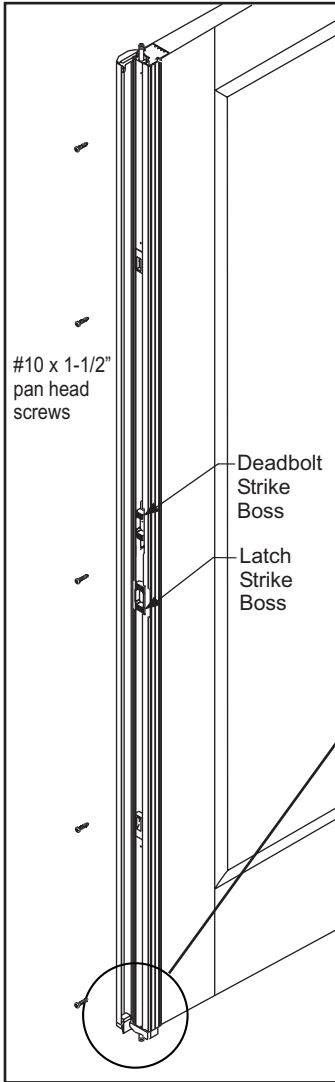

Set Astragal on Door

NOTE: If deadbolt is **NOT** used, deadbolt strike boss should be removed. Press thru back of astragal or slide to latch position and remove.

Align astragal to slab which is to be “fixed”.

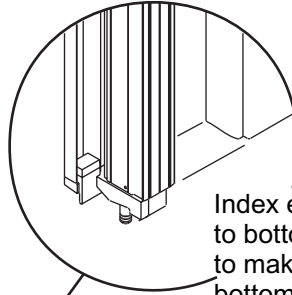

Index end of aluminum to bottom edge of slab to make flush with bottom of door.

Drill and Secure Astragal

Pre-drill for mounting thru the astragal mounting holes into fixed door using 1/8” dia. bit.

For astragals with 17” slide bolts, loosen set screw on retainer using hex key provided, slide bolts and retainers toward center of astragal to expose mounting holes at each end.

Install (2) #10 x 1-1/2” pan head end mounting screws first (per diagram). Then replace retainers flush with astragal ends and tighten set screws.

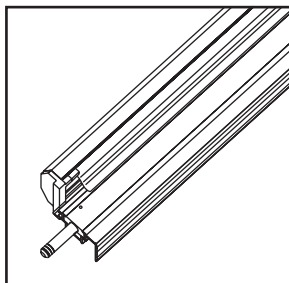
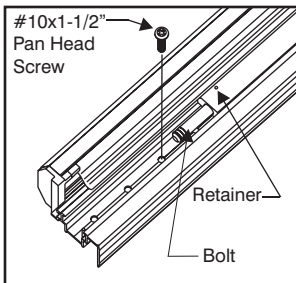

Secure astragal to door lock edge through all exposed pre-punched mounting holes using provided #10 x 1-1/2” pan head screws. (Note: Upper and lower mounting screws also secure bolt spring clip.)

4

ATTACH ASTRAGAL - *continued*

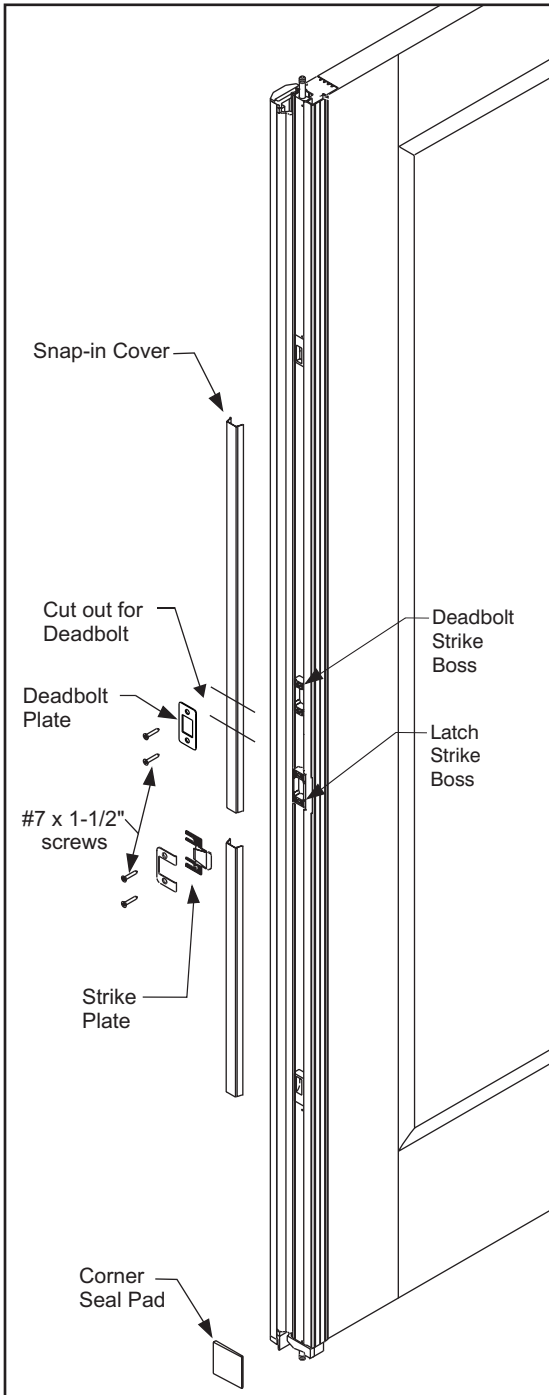

Standard Lock Option

Fasten Strike Plate Assembly

Position latch strike boss at latch centerline and fasten strike plate with (2) #7 x 1-1/2" screws provided.

If deadbolt is used, mark the deadbolt centerline and position deadbolt plate on the astragal.

Holding deadbolt plate in place, pre-drill 2 mounting holes using a 1/16" dia. drill.

Fasten the deadbolt plate with (2) #7 x 1-1/2" screws provided to strike boss.

Apply Snap-In Cover

If deadbolt is used, cut a section from longer snap-in cover to fit between latch and deadbolt strikes, snap it into place, and trim long cover to fit above strike.

Align longer snap-in cover with top of strike plate and snap into place.

Align shorter snap-in cover with bottom of strike plate and snap into place.

Apply Corner Seal Pad



NOTE:
Corner seal pads are only used with inswing units.

Apply corner seal pad against weatherstrip with bottom edge in line with bottom edge of seal. Narrow edge of pad to point toward interior.

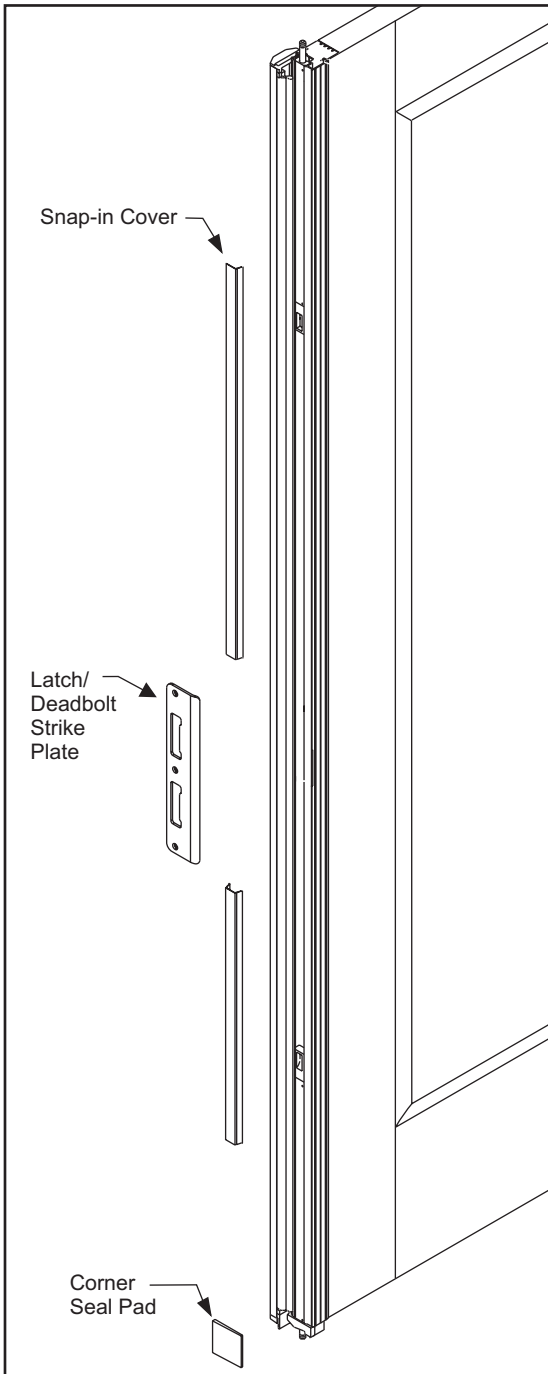
**Multi-point Lock Option*****Fasten Strike Plate Assembly***

Position latch/deadbolt strike plate in mortised pocket on astragal using screws provided in Multi-point Strike Plate Package.

Apply Snap-In Cover

Align longer snap-in cover with top of strike plate and snap into place. Trim as required.

Align shorter snap-in cover with bottom of strike plate and snap into place. Trim as required.

Apply Corner Seal Pad

NOTE:
Corner seal pads are only used with inswing units.

Apply corner seal pad against weatherstrip with bottom edge in line with bottom edge of seal. Narrow edge of pad to point toward interior.

5 INSTALL WEATHERSTRIP

Apply Weatherstrip to Active Frame Parts

Press in kerf with hand.

Head Jambs

Align starting end with head gain.

Fit and secure in place along full length.

Trim finish end flush with end of jamb.

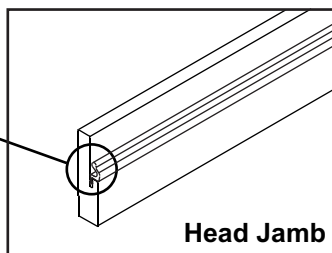

Hinge Jambs

Align starting end with head gain.

Fit and secure in place along full length.

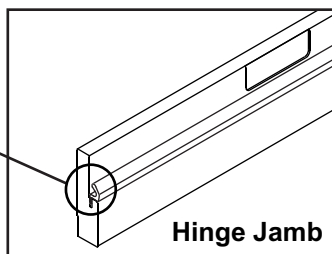

Trim Bottom End

Trim weatherstrip as shown.

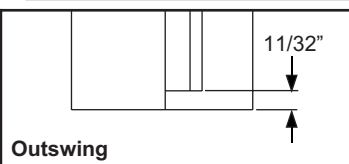
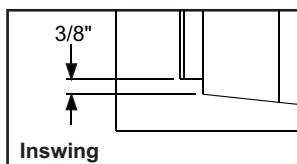

6 ATTACH HINGES TO JAMB



NOTE:

These are instructions for installation of standard hinges. Proceed to step 8, UNIT ASSEMBLY, if using adjustable hinges.

Standard Hinge Option

Fasten Hinges to Hinge Jamb

Place hinges into hinge mortise and pre-drill 1/8" dia. pilot holes through jamb.

Fasten top hinge with (2) #10 x 3/4" flat head screws in hole locations shown.

Fasten middle and bottom hinges each with (3) #10 x 3/4" flat head screws leaving top hole vacant.



CAUTION:

Do not over torque screws.

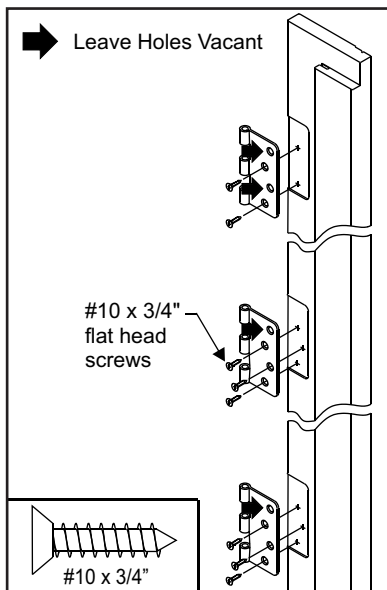

7 ATTACH MULTI-POINT STRIKE PLATES (if applicable)

Head Jamb

Position Multi-point head strike plate into mortise in head jamb.

Mark and drill 3/32" dia. pilot holes into jamb.

Fasten strike plate with #8 x 5/8" flat head screws.

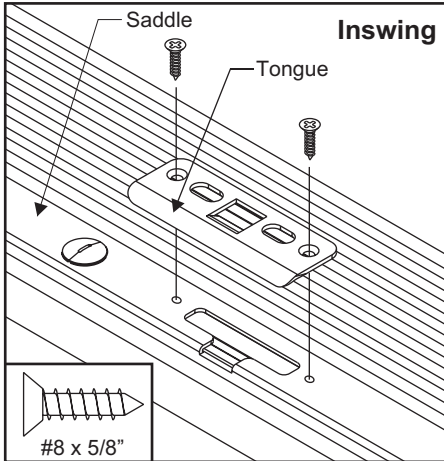
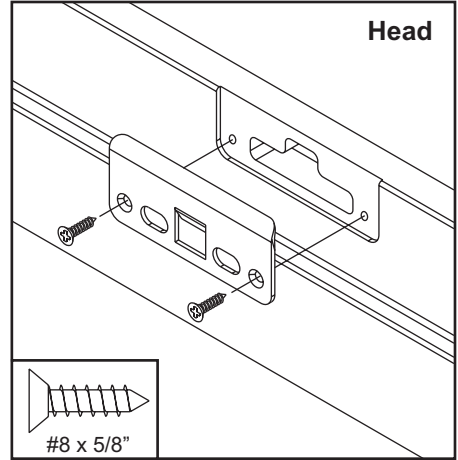

Sill - Inswing

Position Multi-point sill strike on sill over hole with tongue pointing towards interior.

Mark and drill 3/32" dia. pilot holes into sill saddle.

Fasten strike to sill with #8 x 5/8" flat head screws.

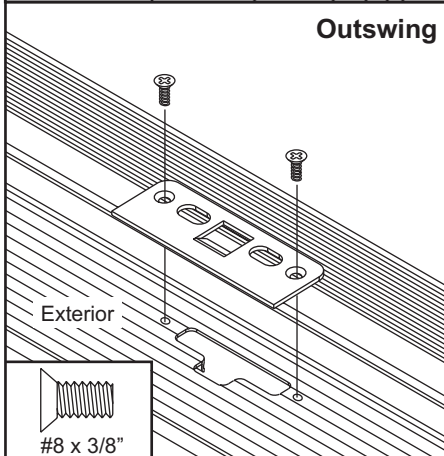

Sill - Outswing

Position Multi-point sill strike on sill over hole with squared edge towards exterior.

Mark and drill 1/8" dia. pilot holes into sill saddle.

Fasten strike to sill with #8 x 3/8" flat head screws.

8 UNIT ASSEMBLY

Standard Hinge Option

Fasten Hinge Jamb to Door Slabs

Lean door panel against table and place jamb on edge of table aligning hinges.

Fasten with 3 hinge pins, inserted at tops of hinges.

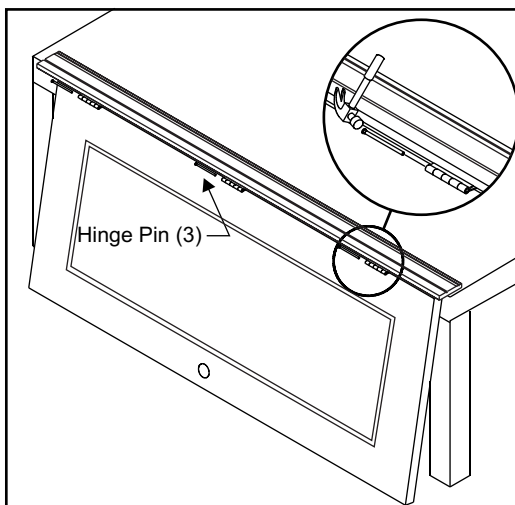

Adjustable Hinge Option

Fasten Frame to Door Panel

Align hinges into mortises in hinge jamba.

Fasten jamba to door panels with #8 x 3/4" flat head screws, (2) in top hinge and (3) in middle and bottom hinge.

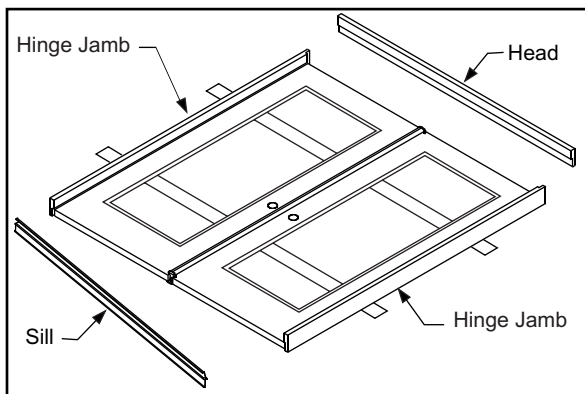
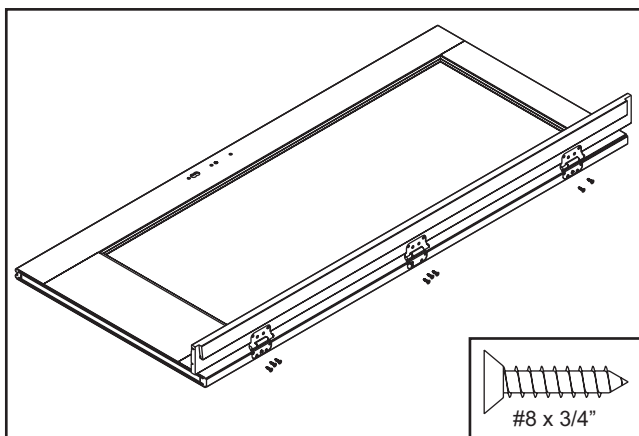

Assemble Double Door Unit

On table, using (2) pieces of 3/4" boards by 6' long as blocks so hinge knuckles do not interfere, lay jamb, doors and astragal subassemblies together.

8 UNIT ASSEMBLY - continued

Fasten Side Jamb to Head Jamb

Butt and align head jamb to side jambs.

Pre-drill 1/8" dia. pilot holes through side jamb into head jamb.

Fasten side jambs to head jamb with (3) #10 x 2 1/2" flat head screws through lock and hinge jamb into head jamb.

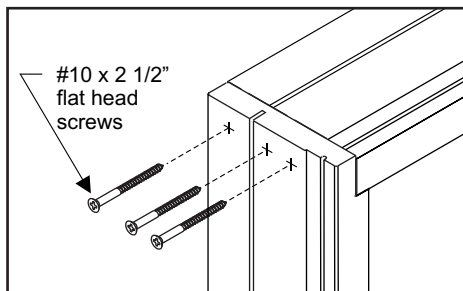

Inswing Sill Option

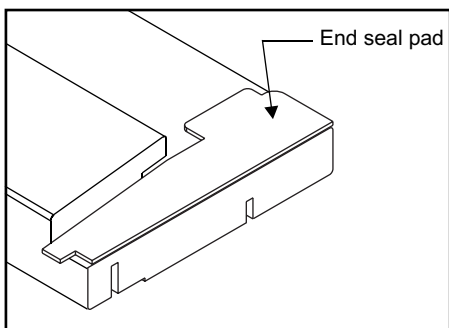

Apply End Seal Pads

Remove from paper backing and apply adhesive side of end seal pads at bottom of each jamb.

Caulk Entire Sill Gain

Apply a 1/4" bead of sealant to sill gain and a bead that matches profile of sill.

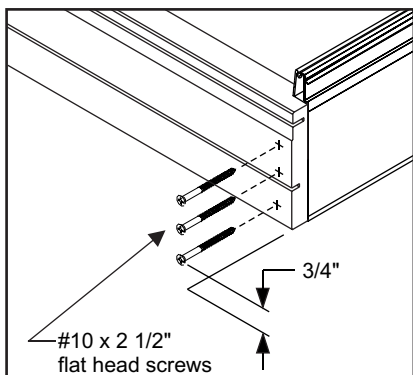
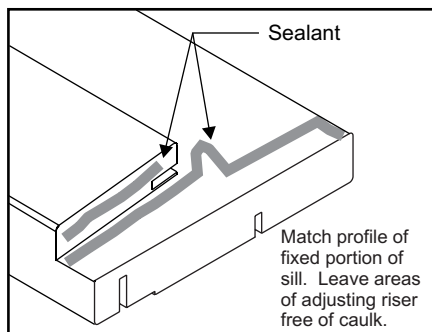

Fasten Sill to Side Jambs

Fit and align sill between lock and hinge jamb.

Starting approximately 3/4" from interior side of jamb, drill (3) 1/8" dia. pilot holes through each jamb into sill substrate.

Fasten each jamb to sill with (3) #10 x 2 1/2" flat head screws.

8 UNIT ASSEMBLY - continued

Outswing Sill Option

Partially Set Sill Screws in Jamb

Drive (1) #8 x 2" flat head screw through holes in both side jamb until tips barely protrude through jamb face.

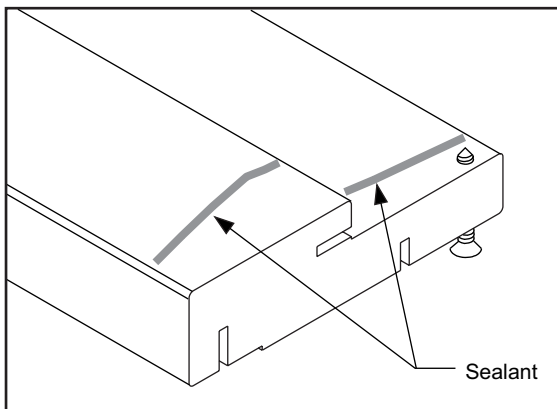
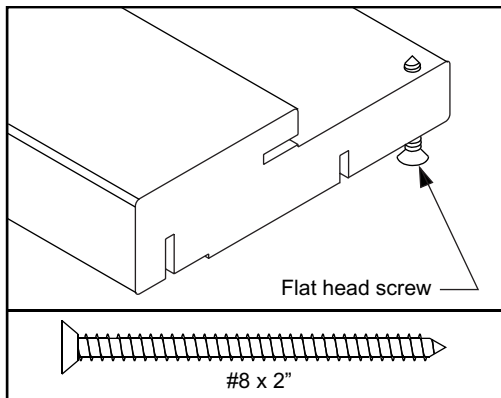

Caulk Entire Sill Gain

Apply a 1/4" bead of sealant to sill gain and a bead that matches upper profile of sill.

Fasten Sill to Jamb

Use screw points and index sill in place.

Drive screws using bit sized properly for screw head.

Pre-drill (2) 3/32" dia. pilot holes through each jamb into sill substrate.

Drive (2) #8 x 2" flat head screws through each side jamb into sill substrate in locations approximately as shown.

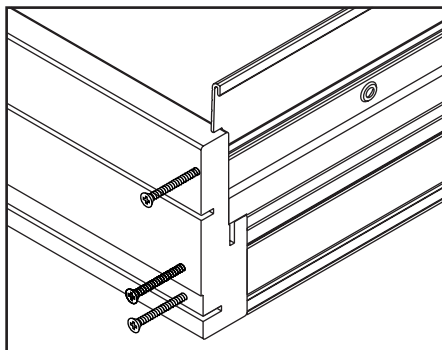

9

FLANGE INSTALLATION

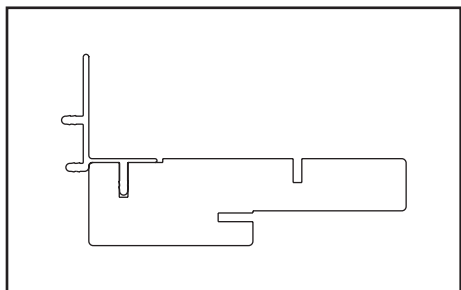

Inswing

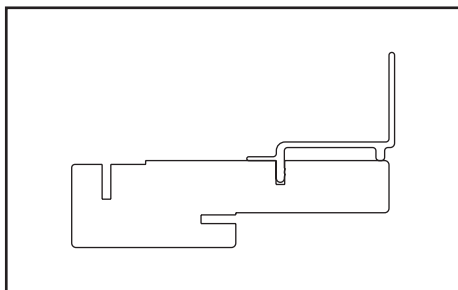

Outswing

NOTE: Inswing application shown.

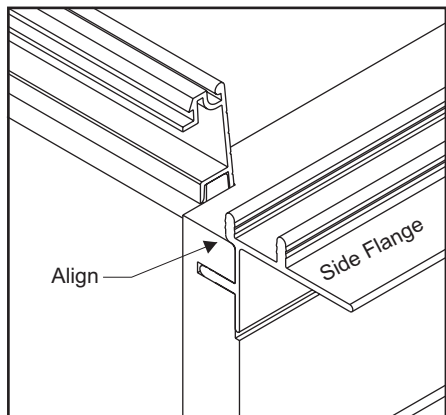

Align and Install Side Flanges

Align edge of side flange with bottom of side jambs.

Firmly press into kerf in jamb using a rubber mallet if necessary.

Flange will be set back approximately 1/2" from top edge of jamb.

Install Top Flange

Center top flange into head jamb kerf and press into place using a rubber mallet if necessary.

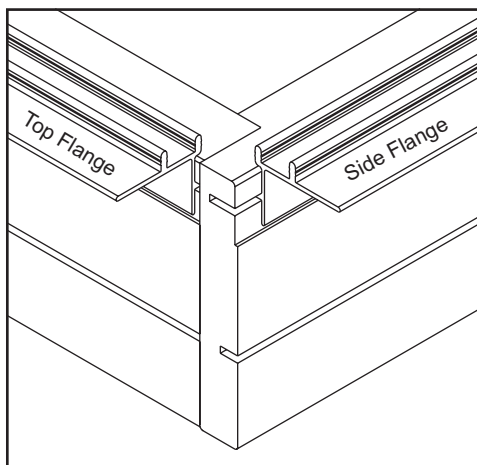

10 ATTACH TRANSPORT CLIP

Flatten lock tab with hammer.

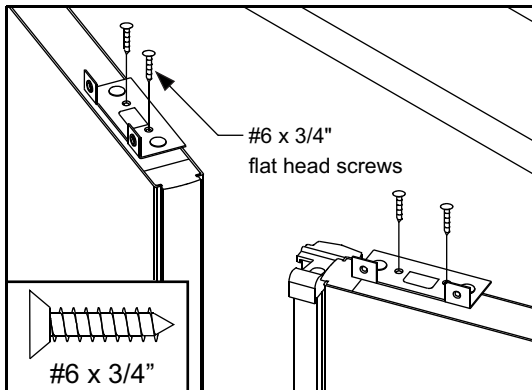
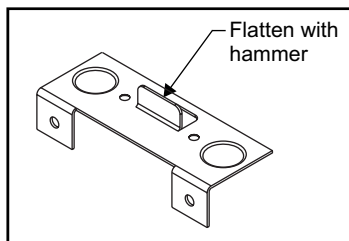

Attach Transport Clips to Top of Door

Open door.

Fasten flattened transport clip to top of door with (2) #6 x 3/4" flat head screws.

Attach Transport Clips to Head Jamb

Close inactive door into frame ensuring margins are even at head jamb.

Fasten transport clip to head jamb with (2) #6 x 3/4" flat head screws.

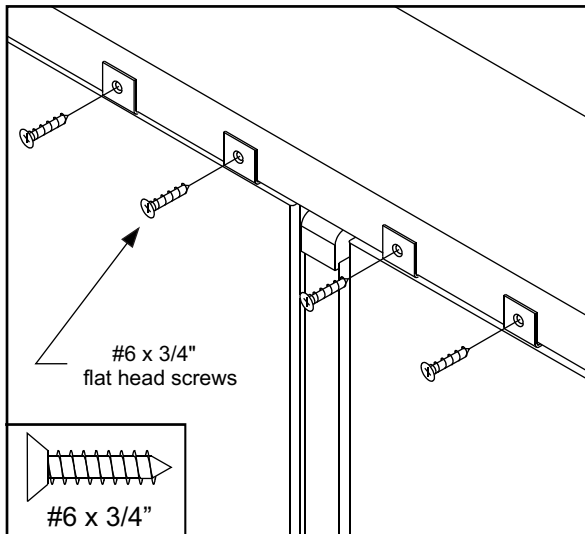

11 UNIT READY FOR INSTALLATION

Unit can now be transferred for installation. Gather any remaining components and hardware as they may be used for installation.

See "Unit Installation" instructions.

THERMA TRU[®]

PATIO DOOR SYSTEMS

1687 Woodlands Dr. Maumee, OH 43537
1-800-THERMATRU (843-7628)
www.thermatru.com